

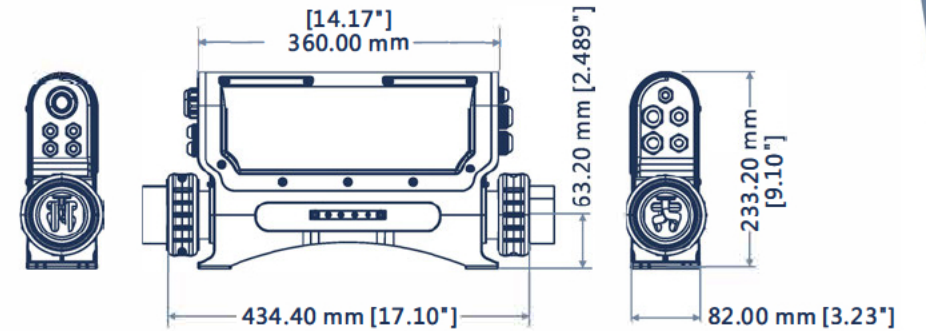

P23B32

CONTROL SYSTEM



SUFFIX	HEATER PARAMETERS
215A	1500W @ 230V~ 50Hz/60Hz
220A	2000W @ 230V~ 50Hz/60Hz
230A	3000W @ 230V~ 50Hz/60Hz
250A	5000W @ 230V~ 50Hz/60Hz

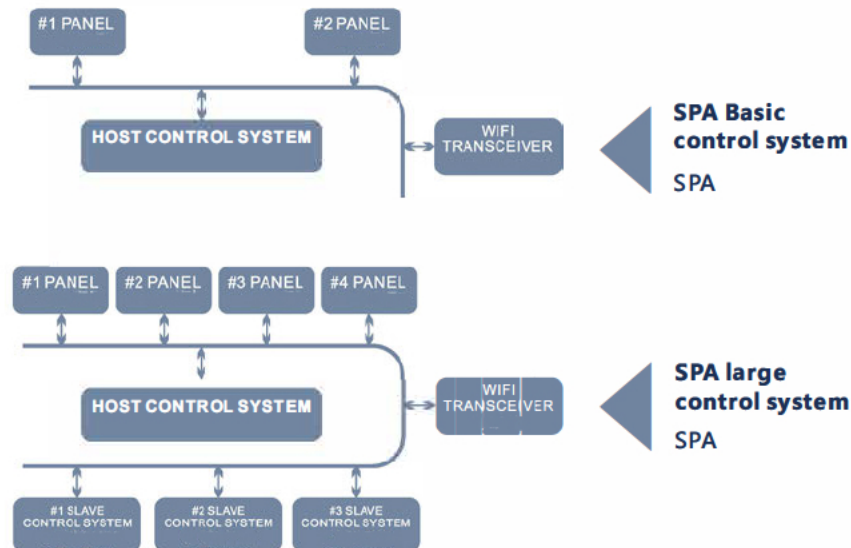

POWER INPUT

- | | |
|--------------------------|--------------------------|
| 1. 220-240V~ 50Hz 1Px32A | 3. 220-240V~ 50Hz 3Px16A |
| 2. 220-240V~ 50Hz 2Px16A | 4. 240V~ 60Hz 45A |

LOAD PARAMETERS

HEATER PUMP OPTION				
CIRC PUMP		LOW SPEED OF PUMP1		
PUMP1(1SPD)	CIRC PUMP*1	PUMP1(2 SPD)	CIRC PUMP	PUMP2
10A MAX	2.5A MAX	HIGH:10A MAX LOW *1:2.5A MAX	N/A	10A MAX

BLOWER	OZONE*1	LIGHT	AUX POWER
10A MAX	1A MAX	12VDC 15W MAX	1A MAX

*1. WHEN POWER INPUT IS 240V~ 60Hz 45A , BY CHANGING JUMPERS CONNECTION, CIRC PUMP AND OZONE (TOGETHER) CAN WORK AT 120V~ 5A OR 240V~ 2.5A.

2. THE SIZE OF THE WATER PIPE JOINT CONNECTED TO THE HEATER CAN BE 2.0 INCH OR 1.5 INCH.