

- SE Monteringsanvisning badkar
DK Monteringsvejledning badekar
NO Monteringsanvisning badekar
FI Kylpyammekehikon ja ammeen asennusohje
GB Installation instructions bathtub
EE Paigaldusjuhised vanniraamidele
LV Uzstādīšanas instrukcija vannām
LT Vonios rėmo montavimo instrukcija
RU Инструкция по монтажу ванны

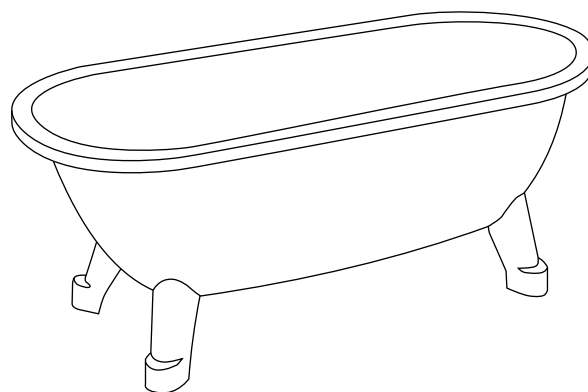
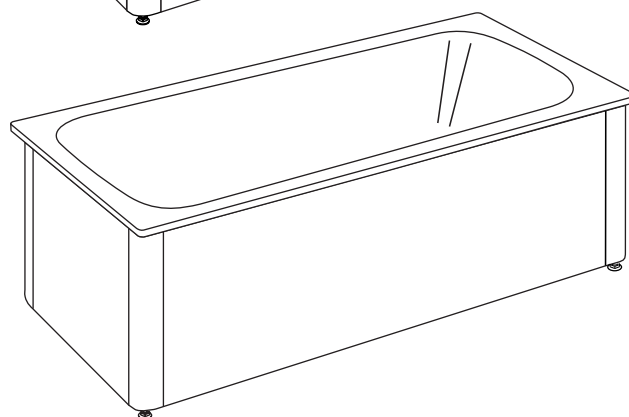
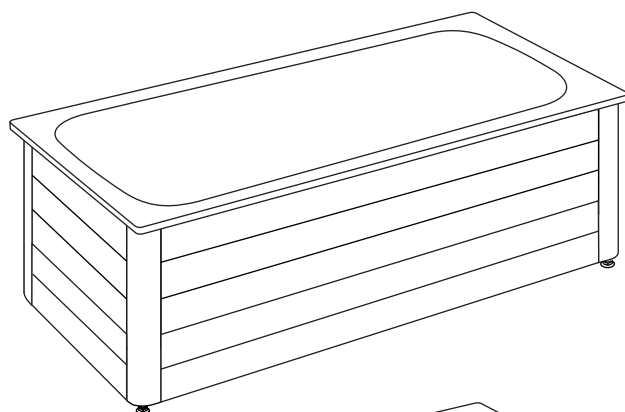

CE

SE Garanti

Produkten har garanti enligt respektive lands gällande branschvillkor.

Direktiv vid reklamation

Våra produkter är tillverkade enligt väldigt stränga kvalitetskrav. Om en produkt trots det är felaktig, ber vi er i första hand att kontakta din återförsäljare. Ärendet underlättas genom att uppvisa kvitto och uppge produktnummer och inköpsdatum.

DK Garanti

Produktet har garanti i forhold til gældende dansk lovgivning.

Vejledning ved reklamation

Vores produkter er fremstillet i overensstemmelse med markedets strengeste krav til kvalitet. Skulle produktet mod forventning være behæftet med fejl henviser vi til den forhandler, hvor produktet er købt. Kvittering skal kunne fremvises, hvis forhandleren forlanger det, ligesom oplysninger om produktnummer og købsdato skal kunne dokumenteres.

NO Garanti

Produktene har garanti i henhold til respektive lands gjeldende bransjevilkår.

Instrukser ved reklamasjon

Våre produkter er produsert i henhold til veldig strenge kvalitetskrav. Om et produkt til tross for dette skulle være feilaktig, ber vi deg vennligst ta kontakt med forhandleren. Vi ber deg medbringe kvittering og oppgi innkjøpsdato samt produktnummer.

FI Takuu

Noudatamme alamme yleisiä toimitusehtoja.

Reklamaatio

Tuotteemme ovat valmistettu Villeroy & Boch ja Gustavsbergin laatuvaatimuksien mukaisesti. Mikäli tuote kuitenkin on virheellinen pyydämme teitä kääntymään ensisijaisesti tuotteen myyjän puoleen. Käsittelyn helpottamiseksi säilyttäkää tosite tuotteen ostosta.

GB Guarantee

The product has a guarantee accordingly to industry rules in every country.

Instructions for complaints

Our products are made according to very strict quality demands. If the product is faulty in spite of that we ask you kindly to take it to your retailer. We also ask you to bring the receipt and be prepared to inform about the product number and purchasing date.

EE Garantii

Antud tootel on garantii vastavalt tehase poolt kehtestatud tingimustele.

Juhised reklamatsioonide käsitlemiseks

Meie tooted on valmistatud silmas pidades väga täpseid kvaliteedistandardeid. Juhul kui olete saanud praaktoote, palume Teil toimetada see kas meie edasimüüja juurde või võtta ühendust esindusega. Samuti palume alles hoida ostutšekk ning vajadusel anda informatsiooni tootenumbri ja ostu sooritamise aja kohta.

LV Garantija

Izstrādājumam ir garantija saskaņā ar ražotāja standartiem.

Instrukcija kvalitātes problēmu gadījumā

Mūsu produkcija tiek ražota pēc ļoti striktiem kvalitātes kritērijiem. Taču – gadījumā, ja produktam tiek konstatēta kvalitātes problēma – lūdzu, sazinieties ar pārdevēju. Lūdzu, esiet gatavi arī uzrādīt pirkuma čeku ar pirkuma datumu.

LT Garantija

Gaminiams garantija suteikiama atsižvelgiant į konkrečios šalies kokybės reikalavimus.

Reklamacijos

Mūsų produkcija pagaminta vadovaujantis griežtais kokybės reikalavimais. Jei gaminys nekokybiškas – prašome jį gražinti pardavėjui, pateikiant pirkimo čekį, gaminio numerį bei nurodant pirkimo datą.

RU Гарантия

Гарантийные условия устанавливаются в соответствии с законами и правилами, которые действуют в стране сбыта.

Рассмотрение рекламаций

Наша продукция соответствует современным стандартам и требованиям к качеству. В случае возникновения неисправности Вы можете обратиться в торговую организацию, где было приобретено данное изделие. При заявлении рекламации необходимо предъявить сопроводительные документы к данной продукции и чек, подтверждающий дату покупки.

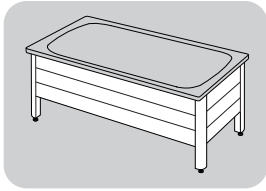

60xx

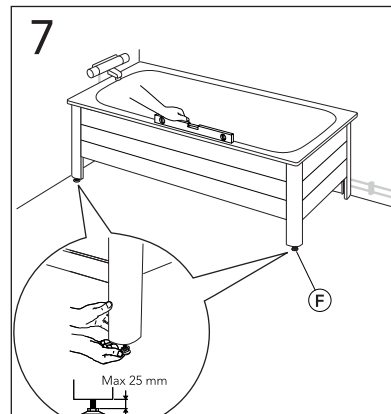
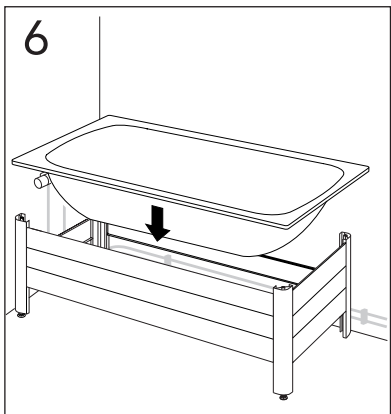
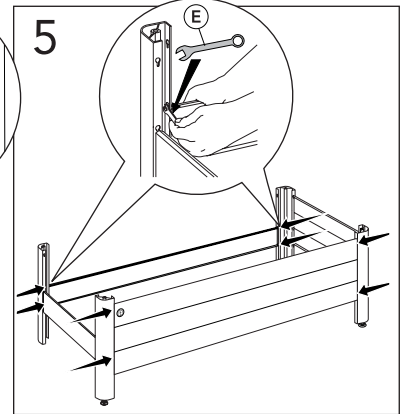
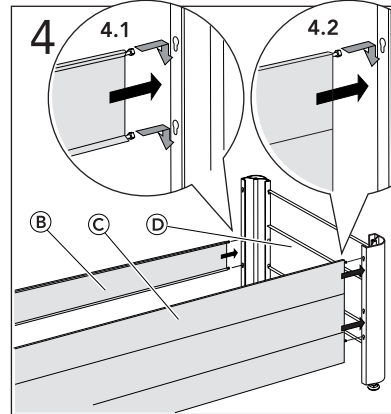
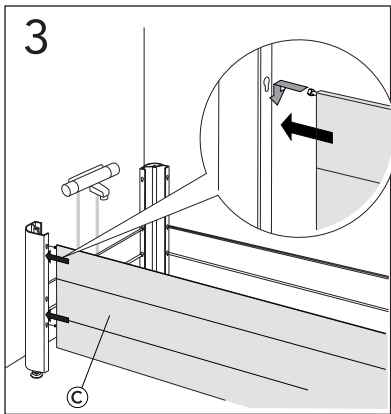
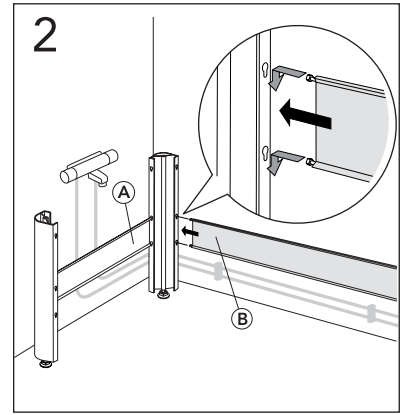
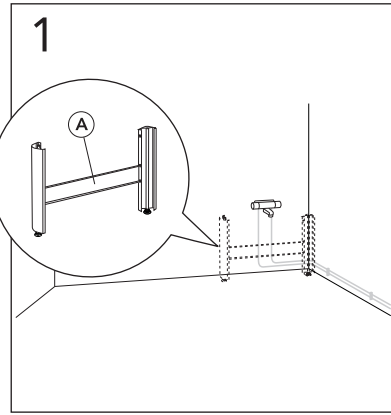
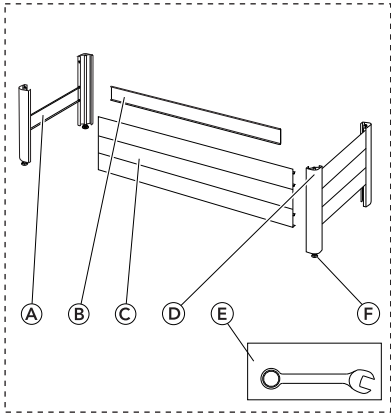

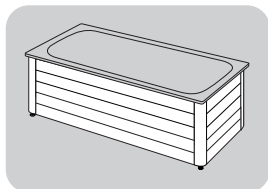

70xx

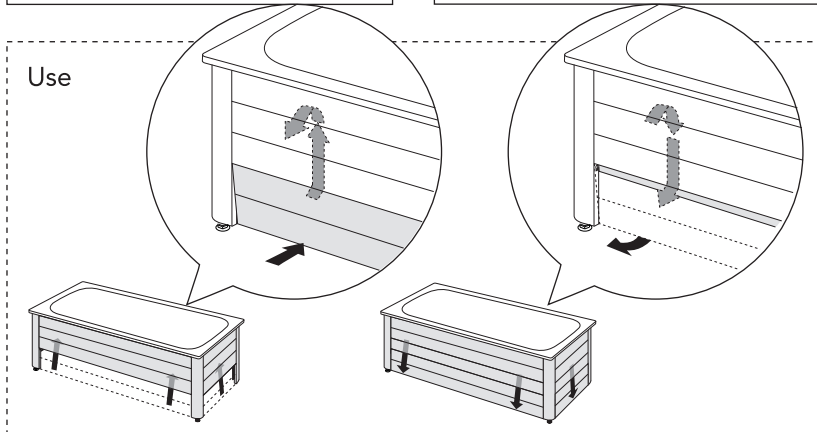
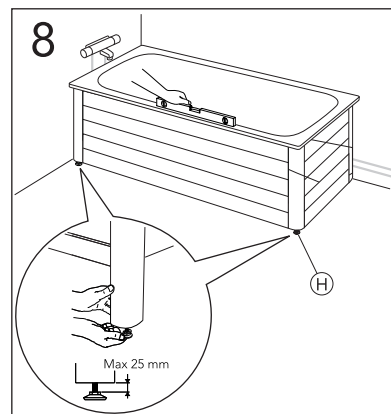
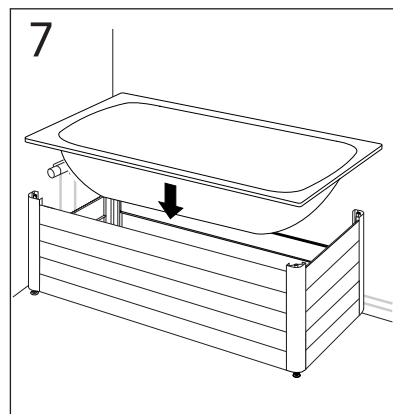
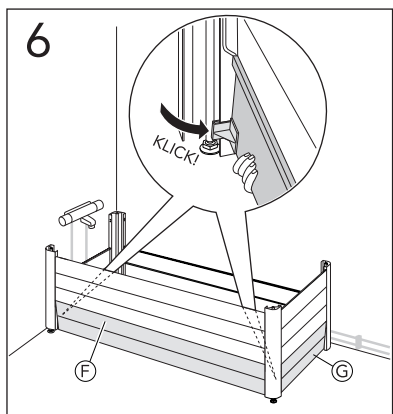
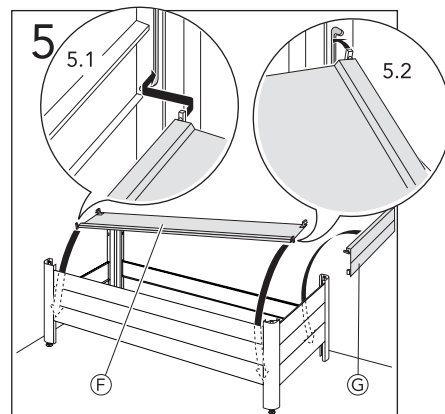
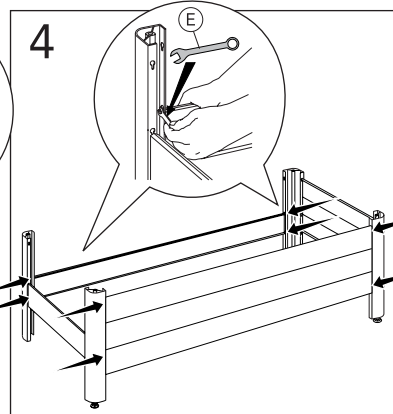
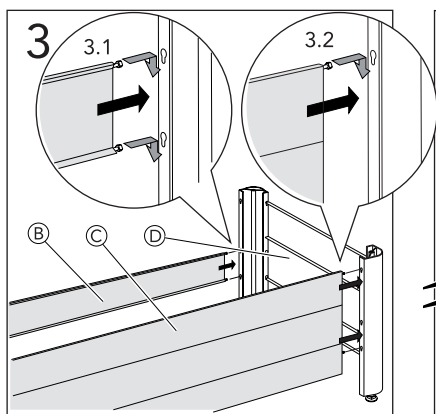
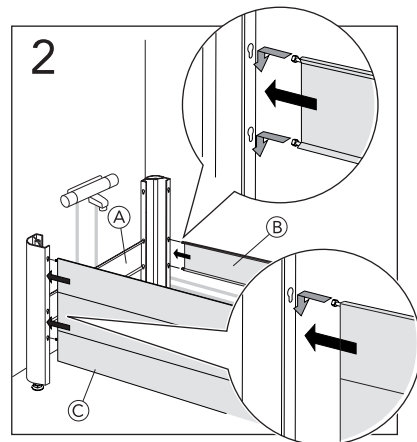
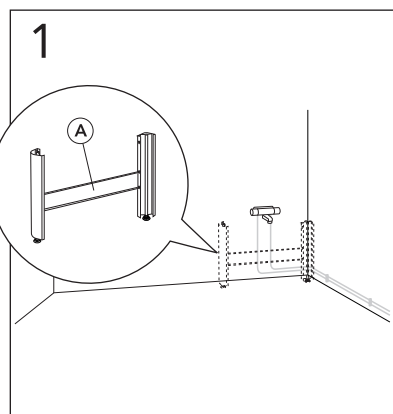
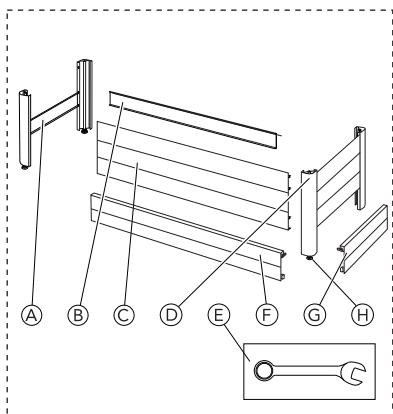

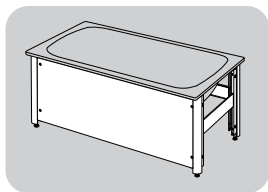

5016/5017

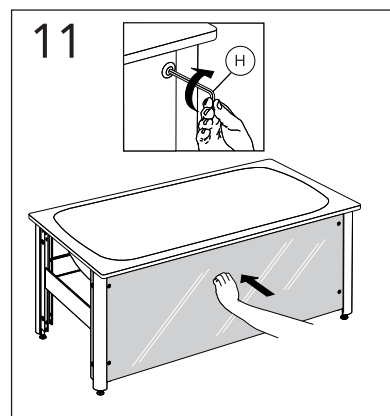
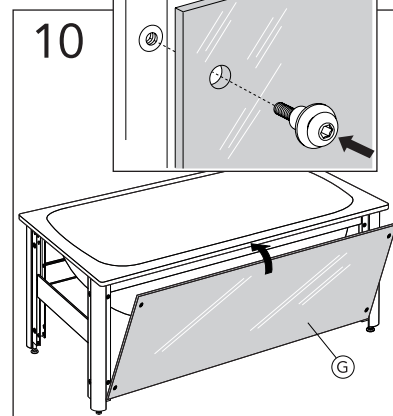
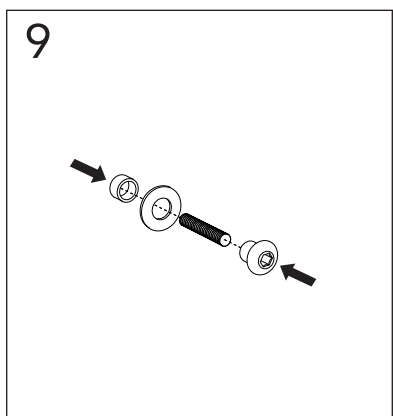
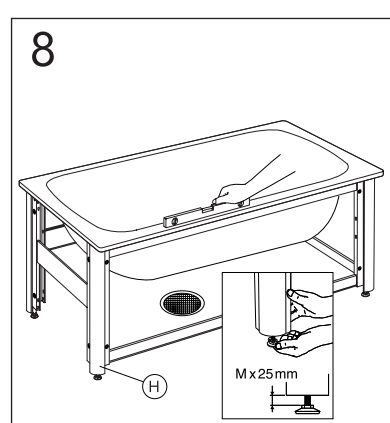
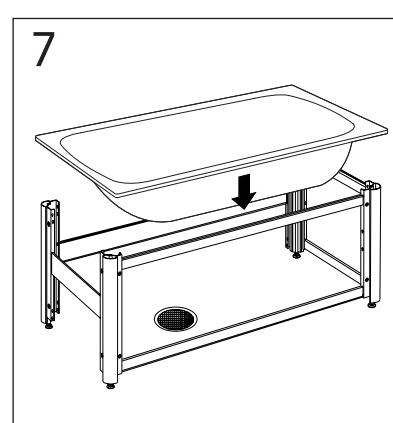
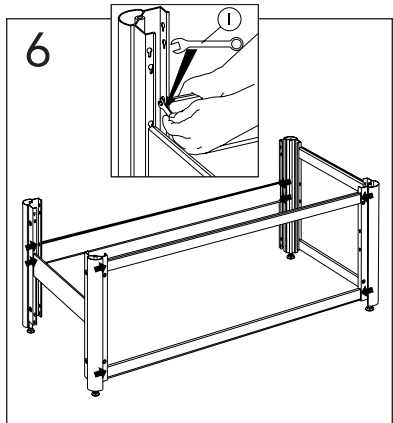
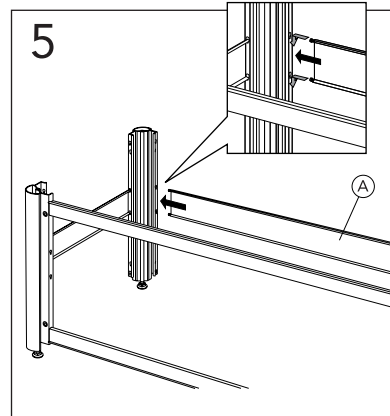
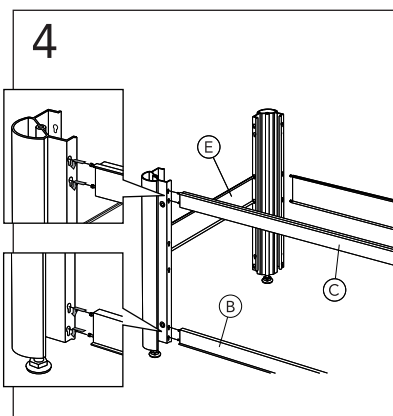
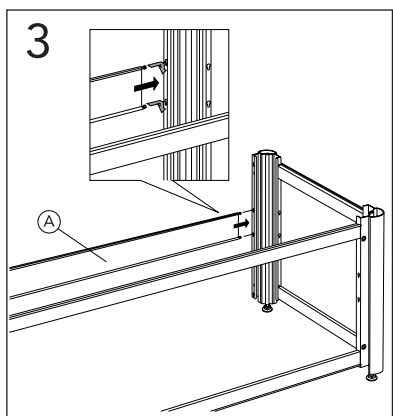
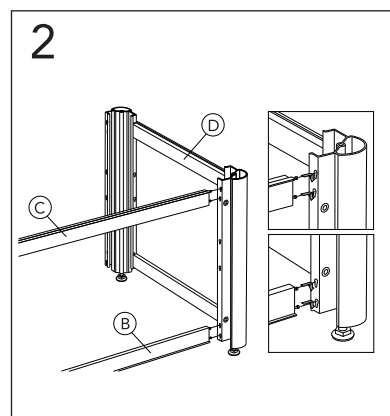
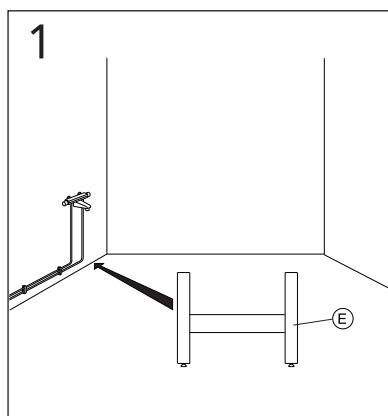
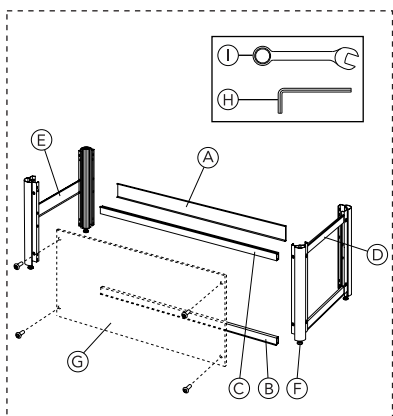

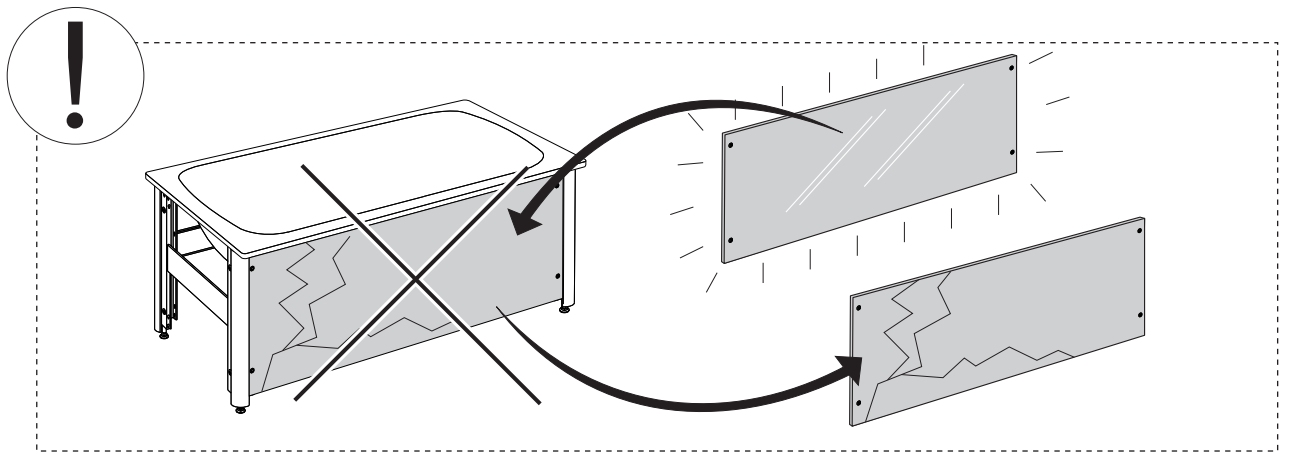
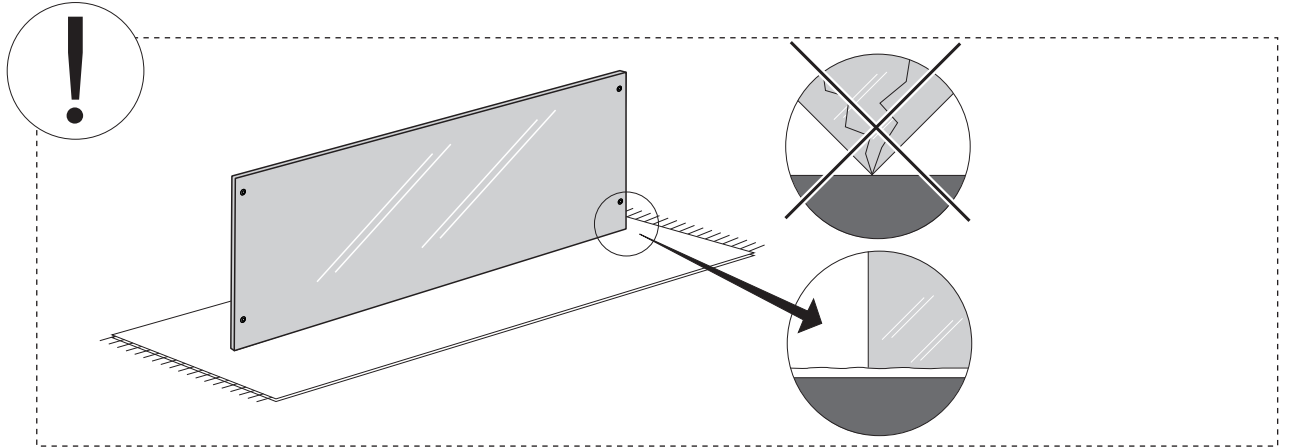

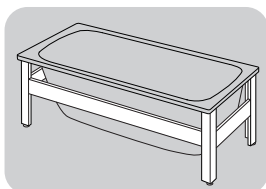

1016

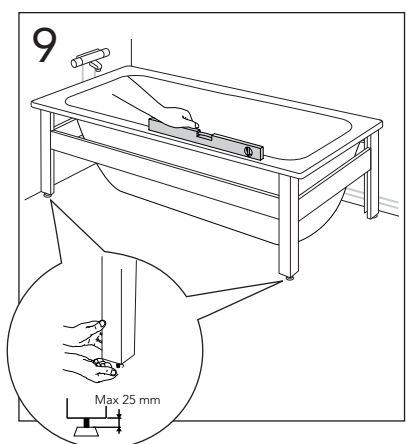
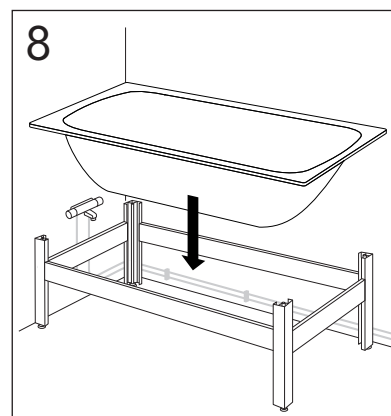
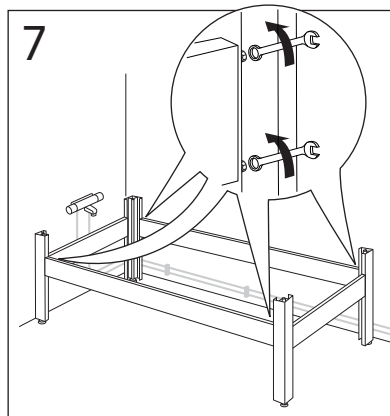
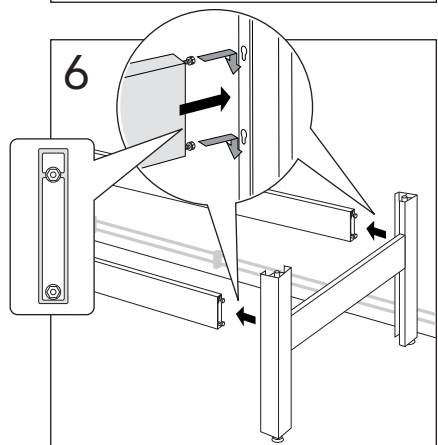
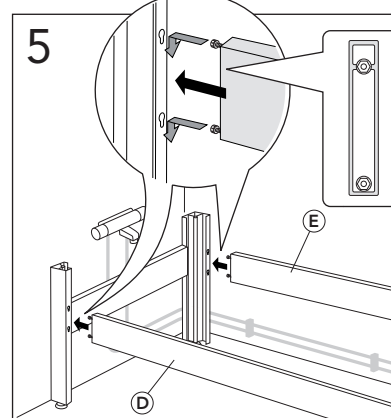
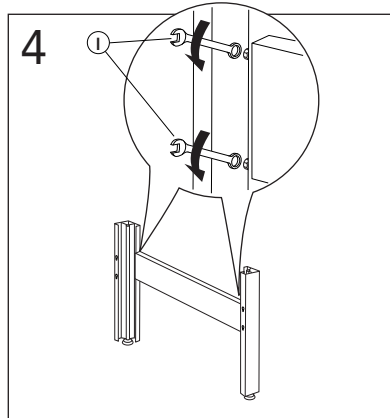
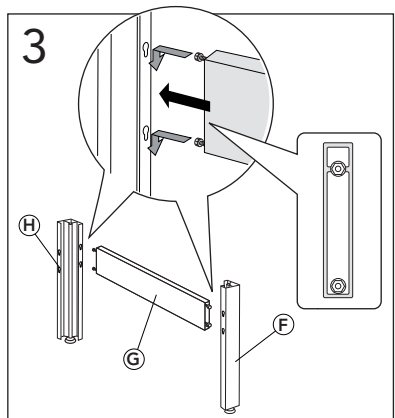
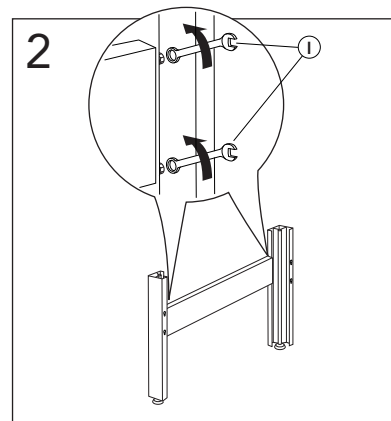
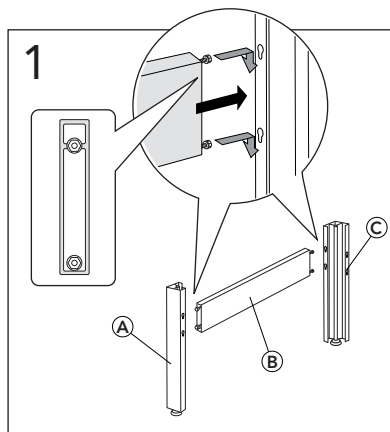
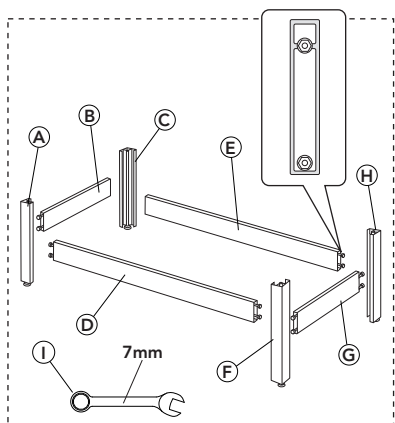

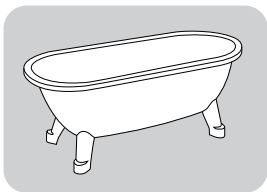

6316/6368

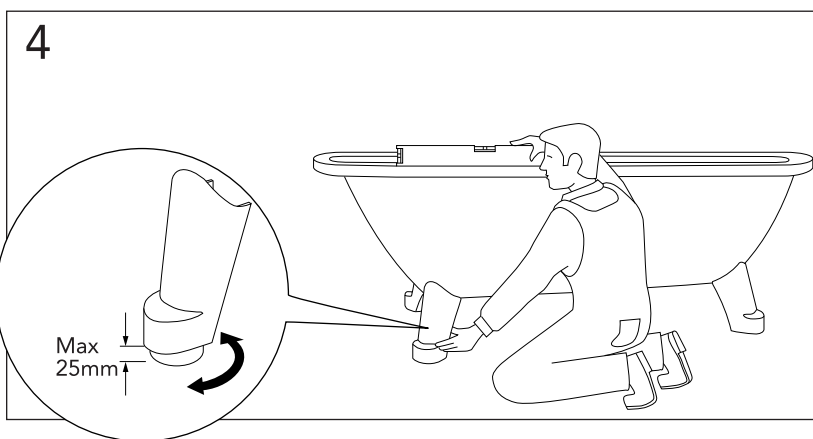
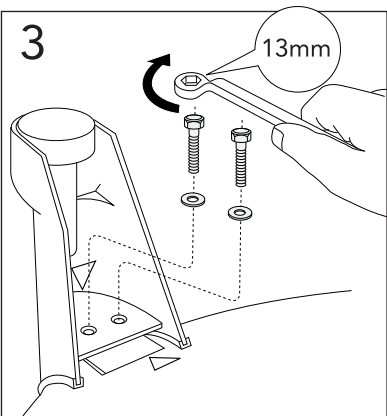
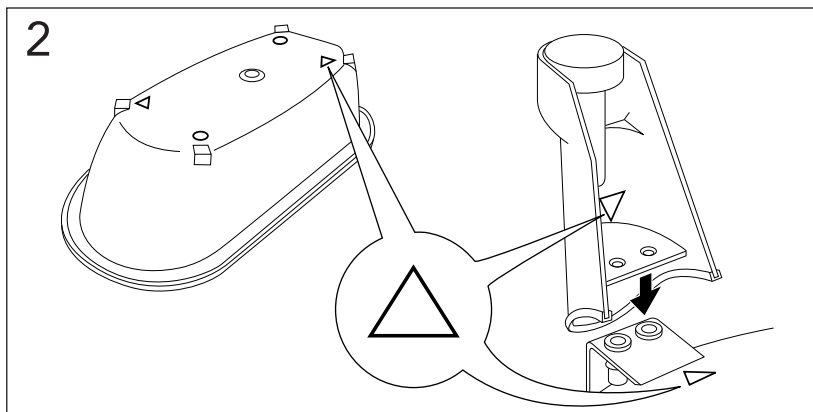
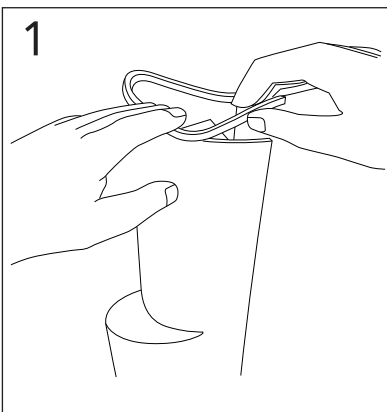
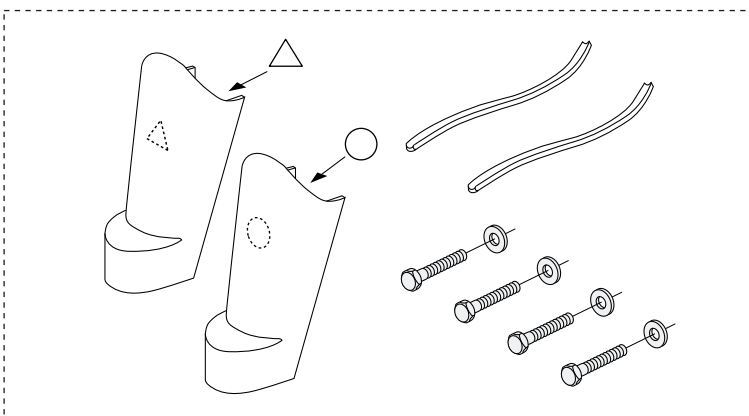

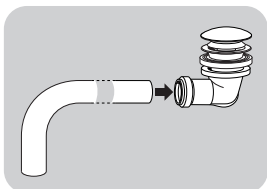

6316/6368 Pop-up

2010-

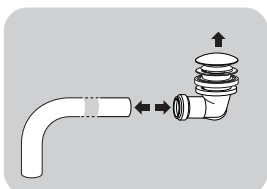
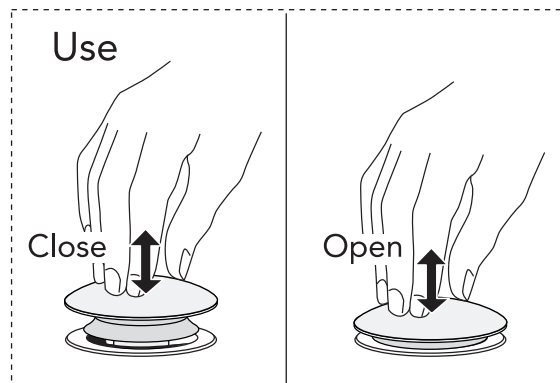
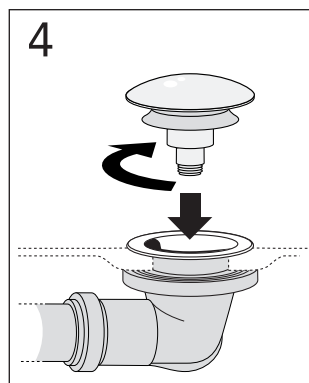
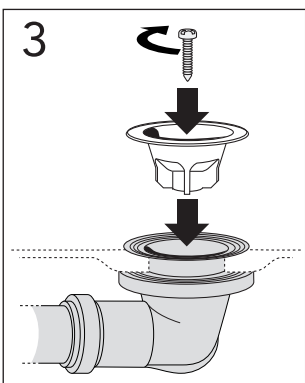
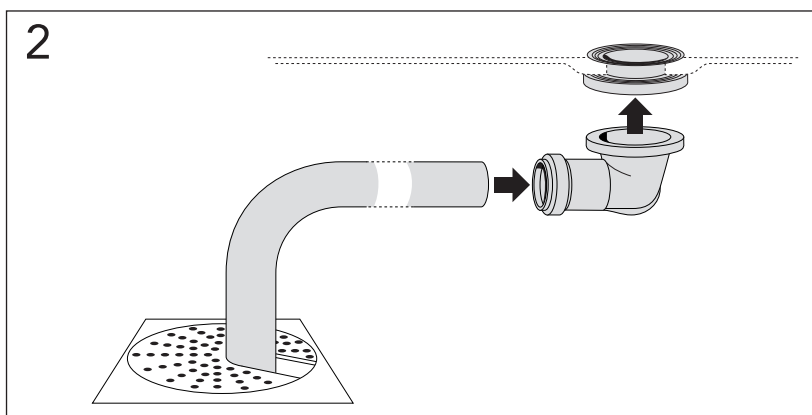
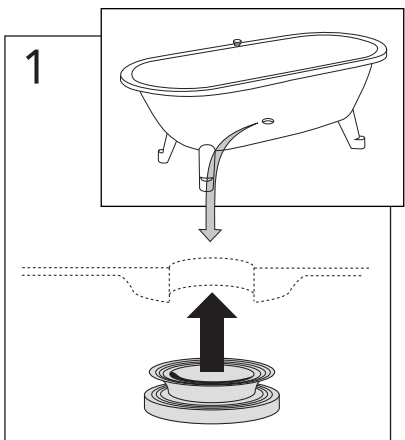

1998 - 2010

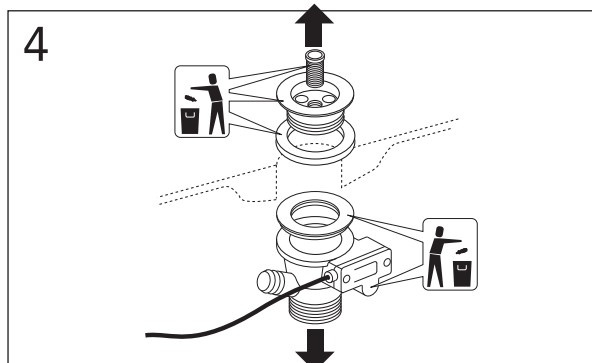
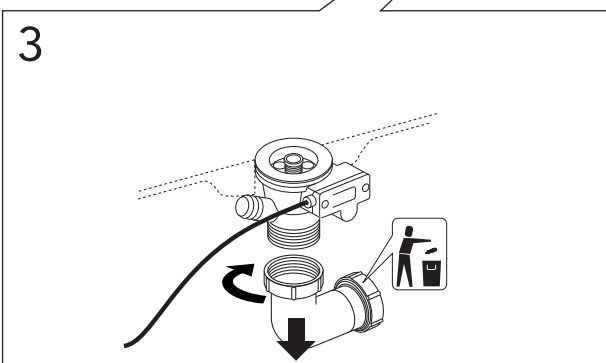
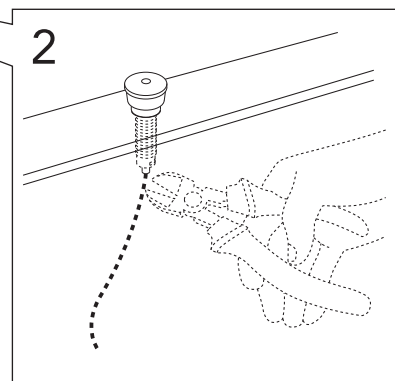
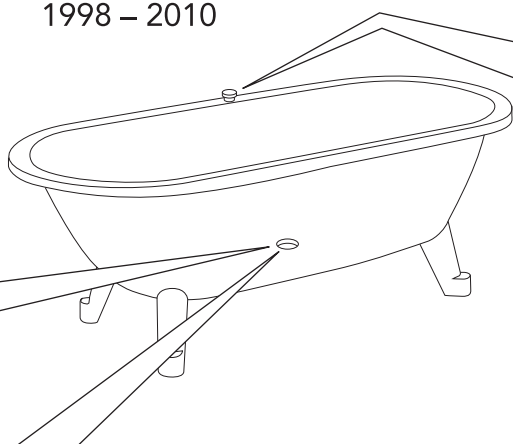
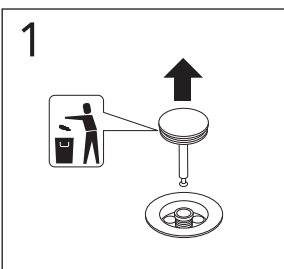



GB2929900174

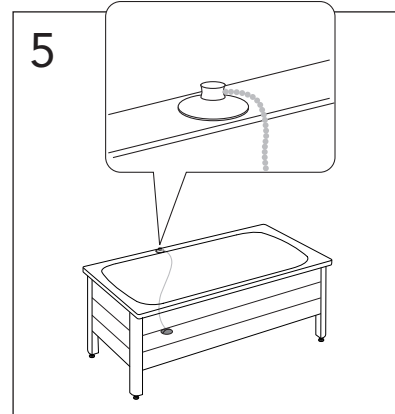
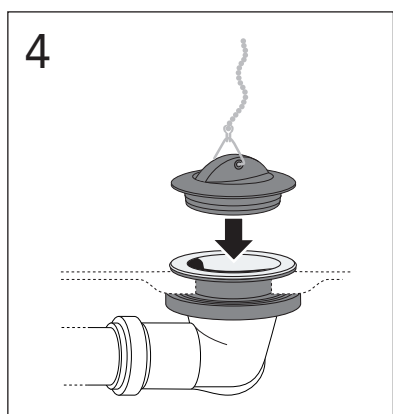
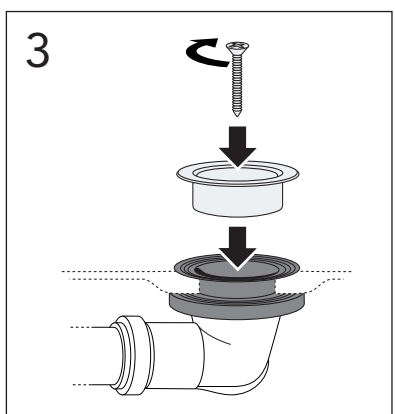
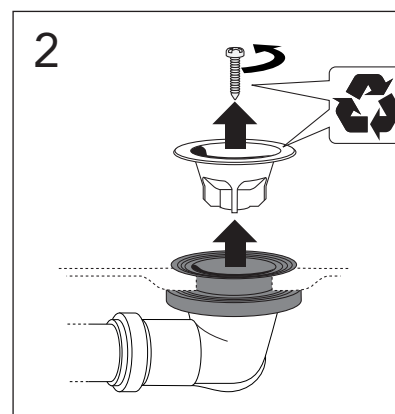
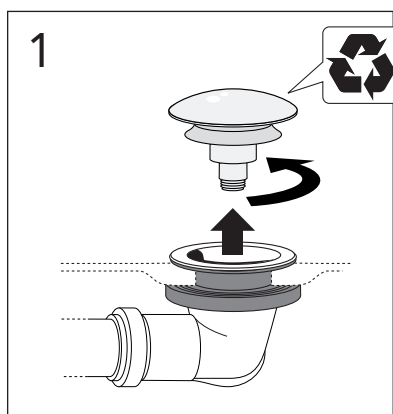
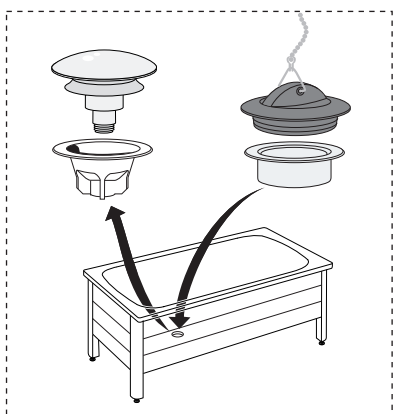

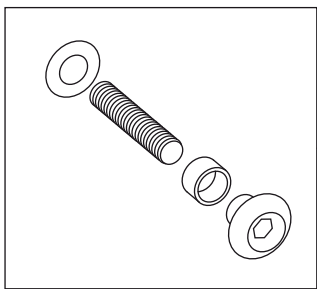

1

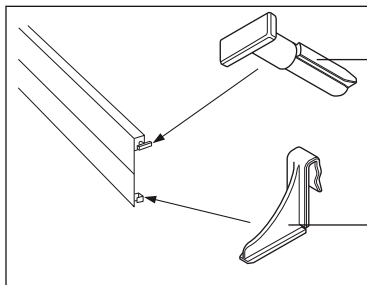

2

3

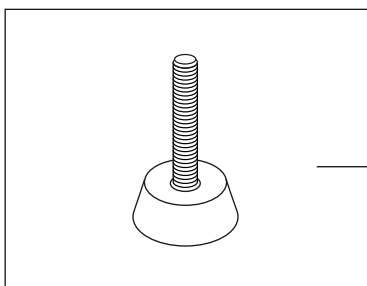

4

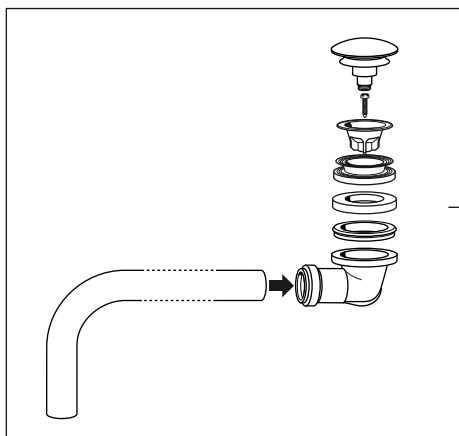

5

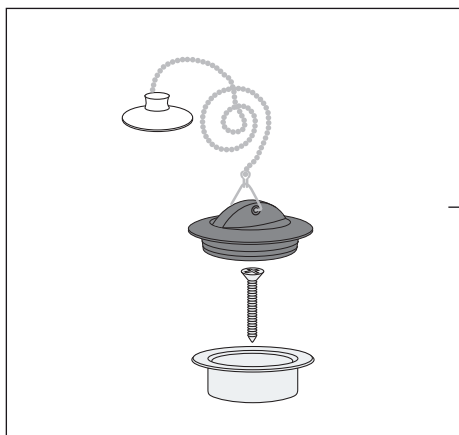

6

Article no.
 1: GB2929920001
 2: GB2929970002
 3: GB2929970001
 4: GB2929970004
 5: GB2929970003
 6: GB2929900174

Skötsel av emaljerade badkar
 Vedlikeholdelse af emaljerede badekar
 Hoito-ohje, emaloidut teräsammeet
 Maintenance of enameled bathtub
 Emaileeritud terasvannide hooldus
 Montāžas un kopšanas instrukcija tērauda vannām
 Emaliuotų vonių priežiūra

МОНТАЖ И ТЕХНИЧЕСКАЯ ПОДДЕРЖКА ЭМАЛИРОВАННЫХ ВАНН

www.gustavsberg.com

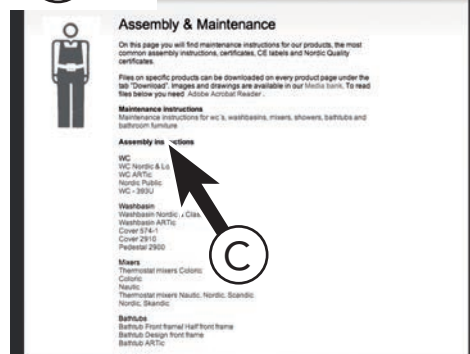

Sweden
 Villeroy & Boch Gustavsberg AB
 Box 400
 134 29 Gustavsberg
 Phone +46 8 570 391 00
 Fax +46 8 570 320 36
 info@gustavsberg.com

Norway
 Villeroy & Boch Norge AS
 Postboks 13
 1471 Lørenskog
 Tlf. + 47 67 97 82 50
 Faks +47 67 97 16 57
 info@gustavsberg.no

Estonia
 Oy Gustavsberg Ab Eesti Filiaal
 Faehlmanni 6
 10125 Tallinn
 Phone +372 646 03 12
 Fax +372 646 0313
 info@gustavsberg.ee

Lithuania
 Oy Gustavsberg Ab Filialas
 Algirdo 75
 LT-03209 Vilnius
 Tel +370 (5) 246 08 10
 Faksas +370 (5) 269 16 20
 info@gustavsberg.com

Россия
 Представительство Gustavsberg
 127287 Москва
 ул. 2-ая Хуторская д. 38А/913
 Тел.: + 7 495 609 6560
 Факс: + 7 495 609 6632
 info.russia@gustavsberg.com

Denmark
 Villeroy & Boch Danmark A/S
 Vallensbækvej 26-28
 2605 Brøndby
 Tlf + 45 36 70 80 55
 Fax + 45 36 72 08 05
 info@gustavsberg.dk

Suomi/Finland
 Oy Gustavsberg Ab
 Laippatie 14 b
 00880 Helsinki
 Puh 09-32 91 88 11
 Fax 09-32 91 88 50
 myynti@gustavsberg.com

Latvia
 Oy Gustavsberg Ab parstavniecibas
 Krasta iela 68 A
 LV-1019 Riga
 Phone +371 272 455 11
 Fax +371 272 455 19
 info.latvia@gustavsberg.com

Україна
 Представництво Gustavsberg
 в Україні:
 01030 Київ, Україна
 вул. Чапаєва 4, оф.17
 Тел. +38 044 493 98 68
 Факс +38 044 494 98 67
 info.ukraine@gustavsberg.com

Россия
 Представительство Gustavsberg
 в Санкт-Петербурге
 в Санкт-Петербурге
 ул. 9-я Советская,
 д. 5, лит. А, пом.8Н.
 193036 Санкт-Петербург
 Тел: + 7 812 326 7896
 Факс: + 7 812 326 7899
 info.russia@gustavsberg.com